

INSTALLATION, OPERATION AND MAINTENANCE INSTRUCTIONS FOR FAIRCHILD MODEL 3400 LEVER OPERATED PNEUMATIC PRESSURE REGULATOR

GENERAL INFORMATION

The Model 3400 consists of Standard Fairchild regulators, with a lever control feature added.

Specifications

Model 3400

Flow capacity 50 SCFM (85 m³/HR)
100 psig [7.0 BAR] (700 kPa) supply;
20 psig [1.5 BAR] (150 kPa) set

Exhaust capacity 8 SCFM (13.6 m³/HR)
downstream pressure 5 psig
[.35 BAR] (35 kPa) above set pressure

Sensitivity 1/2" (1.25 cm) W.C.

Effect of supply
pressure variation less than 0.1 psig
[.007 BAR] (0.7 kPa) for 100 psig
[7.0 BAR] (700 kPa) charge

Supply pressure 250 psig max
[17.0 BAR] (1700 kPa)

Mounting pipe or panel

Ambient temperature limits -40°F to +200°F
(-40°C to + 93.3°C)

PRINCIPLES OF OPERATION

The Model 3400 consists of a cam and plunger assembly on which a Model 1000 Regulator is mounted. When supply air is introduced into the inlet port, it exerts pressure against the supply valve and the top of the inner valve assembly balance diaphragm simultaneously. The two opposite acting forces tend to balance the supply valve assembly, neutralizing the effect of supply pressure changes.

the relief valve. This condition is achieved only when output pressure reaches the desired set point. Until then the downward force opens the supply valve, allowing supply air to be routed to the outlet port. Downstream (outlet) pressure is transmitted through the aspirator tube to the control chamber and sensed by the underside of the control diaphragm. The increase in pressure on the control diaphragm causes the diaphragm assembly to move upward against the force of the range spring acting on the top of the control diaphragm. This force, acting through the connecting tube, allows the supply valve to throttle, maintaining output pressure.

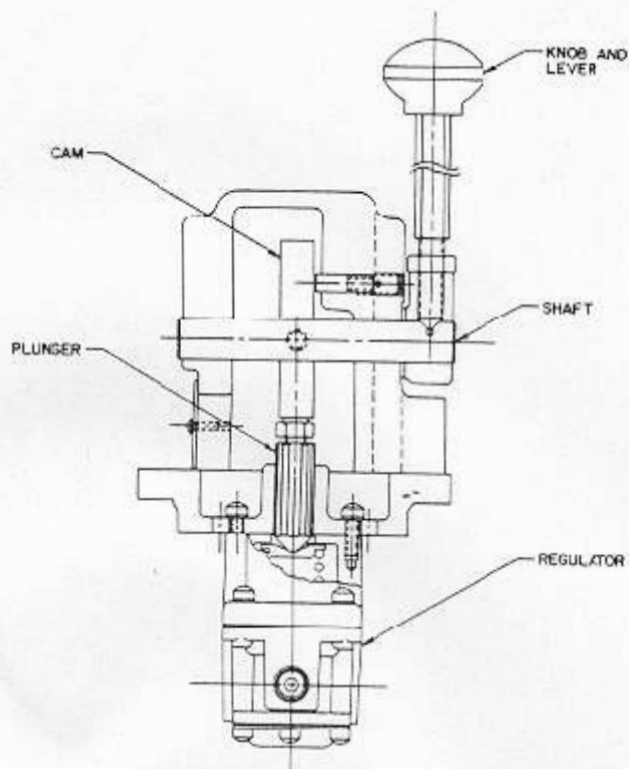

When set point is reached, the force acting on the bottom of the control diaphragm is in balance with the force acting on the top of the control diaphragm. At this point the force (1) due to supply pressure acting on the supply valve and the force (1) due to supply pressure acting on top of the balance diaphragm are in balance. The force (2) due to downstream pressure acting on the top of the supply valve and the force (2) due to downstream pressure acting on the bottom of the relief valve are in balance. If the downstream pressure increases above set point, the increased pressure will be transmitted through the aspirator tube to the bottom of the control diaphragm, causing the diaphragm assembly to move upward and allowing the supply valve to close. The diaphragm assembly continues its upward movement, sliding on the seal tube and allowing the relief valve to open. Because the poppet valve is still closed, pressure will be communicated down the valve pintle to the underside of the motor diaphragm, causing the supply valve to seal even tighter. With the continued increase in downstream pressure, the poppet valve will open and vent the excess pressure to atmosphere. If downstream pressure decreases, the decreased pressure will be transmitted through the aspirator tube to the bottom of the control diaphragm, causing the diaphragm assembly to move downward, closing the poppet valve. As the diaphragm continues to move downward, the end of the pintle will be sealed off and the supply valve will open through the pintle, allowing supply air to be routed to the inlet port and increasing downstream pressure until set point is reached.

When the lever arm of the regulator is manipulated, the range spring exerts a force against the top of the control diaphragm. The force exerted by the range spring produces an output pressure $P_o = K$ where K is the spring constant. This force keeps the relief seat against

INSTALLATION

Clean all pipe lines to the regulator to remove dirt and scale before installation is made. Apply minimum amount of pipe compound to male threads of air line only. Start with third thread back and work away from end of line to avoid possibility of getting compound into regulator. Install regulator in air line; body is threaded $\frac{1}{4}$ " or $\frac{3}{8}$ " NPT for inlet and outlet connections. Regulator can be mounted in any position without affecting its operation. Inlet and outlet connections are labeled on body and should be tightened securely. Avoid undersized fittings that will limit flow through the

regulator and cause pressure drop downstream. The use of a filter to remove dirt and entrained liquid in the air line ahead of the regulator is recommended for best performance. If an air line lubricator is used, it should be located downstream beyond the regulator in order to avoid interference with the regulator performance.

NOTICE

The presence of certain diester oils in the airlines may hasten deterioration of the elastomers and thus decrease the useful life of this unit.

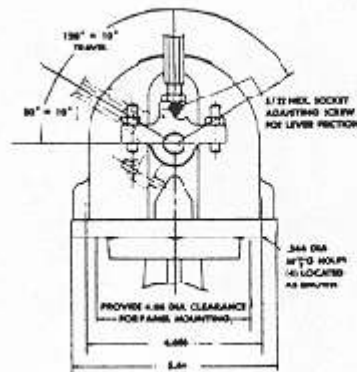
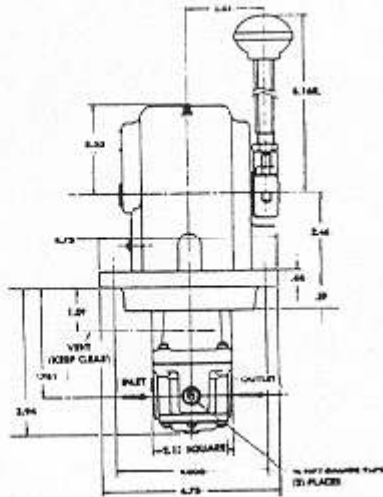

ADJUSTMENTS

No field adjustments are required.

OPERATION

Move the operating lever to zero output pressure position before putting regulator into service for the first time. To operate, move the operating lever slowly until required downstream pressure is obtained. The lever operates a cam inside the unit which compresses the range spring causing increased output pressure. For

decreased output pressure, move the operating lever in the opposite direction. Tension to hold the operating lever in position can be adjusted by turning the set screw in the housing on the lever side. Turning the screw clockwise increases the tension and counter-clockwise reduces the tension.

MAINTENANCE

The regulator is easily disassembled for the occasional cleaning or removal of foreign matter. Before this is done, close shut off valve upstream of the regulator to prevent escape of air when regulator is disassembled. There is no need to remove the regulator from the pipe line; remove the screws at the bottom of the unit that fasten into the body and pull out the inner valve assembly. Wash inner valve assembly with solvent exercising care to avoid damaging diaphragms and valve facings. Replace assembly carefully. The small vent hole in the exterior part of the inner valve assembly must be open. The vent hole in the bonnet

above the base of the unit must also be open at all times. A slight bleed flow of air through the vent hole of the bonnet is necessary for proper operation of the unit.

The cam located inside the top case operates a push rod which is lubricated at the Factory. If field lubrication is required, remove the large screws holding the case together and apply a few drops of machine oil to the push rod. Also apply oil to the outer ends of the operating shaft to which the operating lever is attached. Do not apply more than a few drops.

SERVICE KIT INSTALLATION

Index	Part No.	Description
1		Housing Assembly
1A	EB-8428-1	Push Rod Assembly
2	EB-15949-12	Screw
3	EA-1032-10	Screw
4		Screw
5	EB-8520	Bonnet
6	EC-8424	Base
7	EB-1122	Spring Seat
8	EB-1123-()	Spring
*9	EB-1143	Control Diaphragm Assembly
10		Screw
11	EB-1136-1	Seal Plate Assembly
*12	EB-1106	Seal Plate Gasket
13	EB-1101	Body Assembly
*14	EB-8086-1	Inner Valve Assembly
15	EB-1032-12	Screw

1. Check parts in Service Kit EA-12158 against the parts marked with an asterisk in the Table and exploded view.
2. Mark housing assembly (1), base (6) bonnet (5) and body (13) to assure proper reassembly.
3. Loosen two screws (2) holding housing assembly (1) to base (6) and remove housing assembly (1).
4. Lift out push rod assembly (1A) and set aside.
5. Loosen two screws and lockwashers (3) holding base (6) to bonnet (5) and remove base (6).
6. Loosen four screws (4) holding bonnet (5) to body (13).
7. Remove bonnet (5) from body (13). Remove spring seat (7) and range spring (8) and set aside.
8. Lift off diaphragm assembly (9) and discard.

CAUTION: There are six screws in the bottom plate of inner valve assembly (14). The two screws in line with the PORTS are not to be removed; they hold the assembly together.

9. Remove four screws and lockwashers (15) holding inner valve assembly (14) to body (13).
10. Pull inner valve assembly (14) and supply seat () from body (13). Remove four screws (10) fastening seal plate assembly (11) to body (13).
11. Remove seal plate assembly (11) from body (13) by twisting carefully so that aspirator comes out of the OUT port.
12. Remove seal plate gasket (12) and discard.
13. Secure seal plate gasket (12) from Service Kit and place in body (13) with cutout facing OUT port. Place seal plate assembly (11) into body (13) so that aspirator is in the OUT port. It will require twisting of the assembly to accomplish this.
14. Fasten seal plate assembly (11) to body (13) with four screws (10).
15. Secure inner valve assembly (14) from Service Kit and place in body (13). Fasten inner valve assembly (14) to body (13) with four screws (15).
16. Secure control diaphragm assembly (9) from Service Kit and place on body assembly (13), hexagonal nut facing down. Align four holes in diaphragm assembly (9) with four holes in body (13).

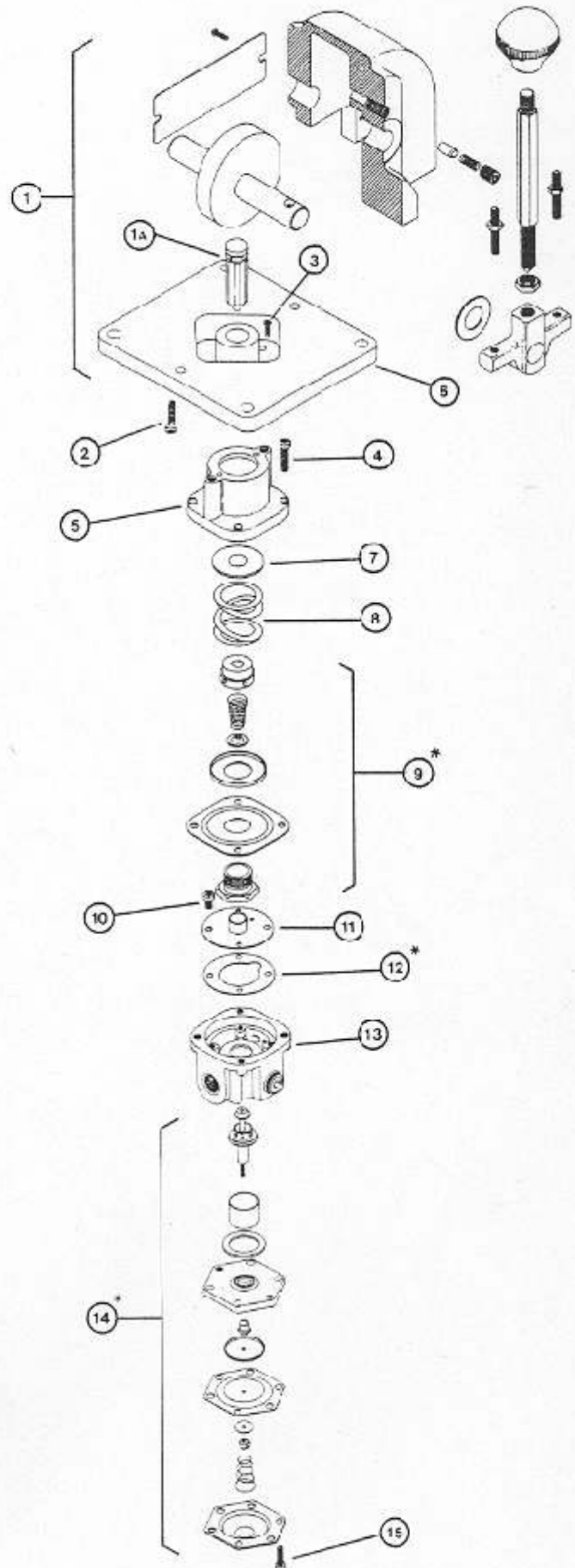

17. Place base (6) on bonnet (5) with two screws (2).
18. Place spring (8) in cup of control diaphragm assembly (9) and place spring seat (7) on top of spring (8), center indentation facing up.
19. Align marks on body (13) and bonnet (5) placed in step 2. Align four holes in bonnet (5) with holes in diaphragm assembly (9) and fasten body (13) to bonnet (5) using four screws (4).

20. Place push rod (1A) into bonnet (5).
21. Align marks on base (6) and housing assembly (1) made in step 2 and fasten housing assembly (1) to base (6) using two screws (2).
22. Reinstall the regulator in accord with installation instructions in the IOM and follow instructions in the Operation section for placing the regulator back into service.

TROUBLE SHOOTING

Problem	Check
Leakage	Body screw tightness Diaphragm
High Bleed	Relief pintle and relief seat for damage or contamination
Difficult to Adjust	Adjusting screw and ball Seal ring lubrication

REPAIR PARTS LIST

Service Kit EA-12158 is available for maintenance of the Model 3400.

LEGAL NOTICE:

The information set forth in the foregoing Installation, Operation and Maintenance Instructions shall not be modified or amended in any respect without prior written consent of Fairchild Industrial Products Company. In addition, the information set forth herein shall be furnished with each product sold incorporating Fairchild's unit as a component thereof.



382 Lancaster Avenue • PO Box 4006 • Malvern, PA 19355
 Phone: 610-647-5700
 Fax: 610-647-3905
 E-mail: corp@tristatech.com
 Web: <http://www.tristatetechnicalsales.com>



FAIRCHILD
 INDUSTRIAL PRODUCTS COMPANY
 3920 WEST POINT BLVD. WINSTON-SALEM, NC 27103-6708
 TEL 336-659-3400 FAX 336-659-9323



ISO 9001:2000
 FM NO. 25571

www.fairchildproducts.com

IS- 10003400
 Litho in USA
 Rev. F 11/02