



The Model 10 is designed for applications that require high capacity and accurate process control. A poppet valve which is balanced by utilizing a rolling diaphragm, insures a constant output pressure even during wide supply pressure variations. Stability of regulated pressure is maintained under varying flow conditions through the use of an aspirator tube which adjusts the air supply in accordance with the flow velocity.

Features

- Control sensitivity of 1/8" water column allows use in precision processes.
- Pressure balanced supply valve prevents supply pressure changes from affecting the setpoint.
- Optional check valve permits dumping of downstream pressure when supply is opened to atmosphere.
- Separate control chamber isolates the diaphragm from the main flow to eliminate hunting and buzzing.
- An aspirator tube compensates downstream pressure droop under flow conditions.
- Canadian Registration Number (CRN) certification for all territories and provinces.

Operating Principles

The Model 10 Series regulator use the force balance principal to control the movement of the Valve Assembly that controls the output pressure. When the regulator is adjusted for a specific set point, the downward force of the Positive Bias Spring moves the Diaphragm Assembly downward. The Supply Valve opens and allows air to pass to the Outlet Port. As the set point is reached, the downward force exerted by the Positive Bias Spring is balanced by the force of the downstream pressure that acts on the Diaphragm Assembly. The resultant force moves the Supply Valve upward to reduce the flow of air to the Outlet Port.

Outlet pressure is maintained as a result of balance between forces acting on the top and bottom of the Diaphragm Assembly.

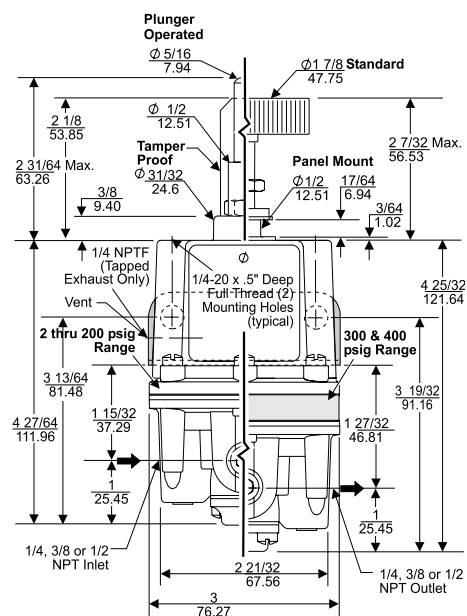
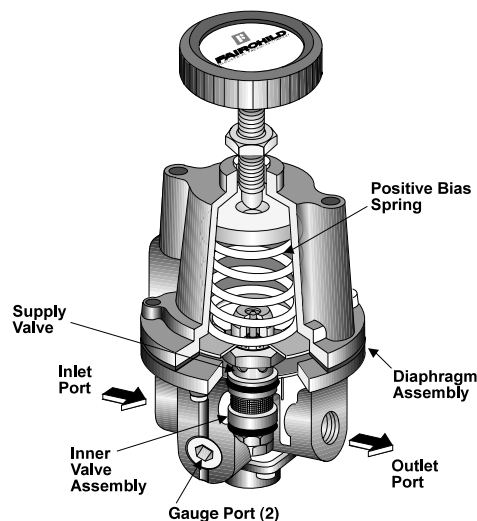

Options

Low Bleed (B)

Option that reduces the bleed rate below that of a standard unit and can be used when bleed or consumption is an issue. A reduction in sensitivity will result from the lower bleed rate.

Low Flow (L)

Option that increases the bleed rate above that of a standard unit to improve response in low flow applications.

Check Valve (C)

Internal check valve that permits rapid dumping of downstream pressure through the supply line and exhaust port when supply pressure is removed.

Non-Relieving (N)

Option that includes no relief function or continuous bleed. Units with this feature must operate with a continuous downstream flow to regulate properly and prevent the output from equalizing with supply line pressure.

