



Features

- Sensitivity of 1/2" (1.27 cm) of water. Responds to equally minute changes in downstream pressure.
- Venturi-type aspirator tube to aid stability and minimize downstream pressure droop under flowing conditions.
- Balanced supply valve to minimize effect of supply pressure variation.
- Control Chamber isolates the control diaphragm to eliminate hunting and buzzing.
- Operates equally well on shop air or clean, dry instrument air.
- May be serviced and maintained without removal from line.
- Mounting Bracket available

Operating Principles

The Model 100 High Flow Pressure Regulator is designed for use in control systems requiring unusually high flow capacities. Like many of the Fairchild regulators, the compensating action of the inner valve assembly of the Model 100 allows complete stabilization of downstream pressure.

This high quality unit, which operates as efficiently on shop air as on dry instrument air, offers unusual versatility and economy. The Model 100 is capable of providing precise control of set point and good sensitivity under high flow conditions, and is the ideal choice for many demanding applications, including main header regulator control, large nip roll loading, and clutch brake operation.

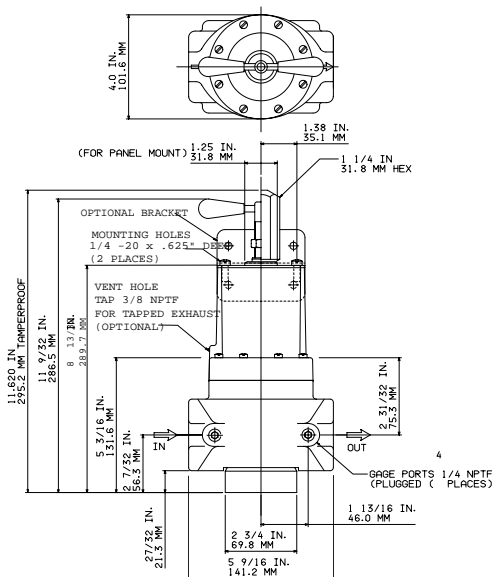
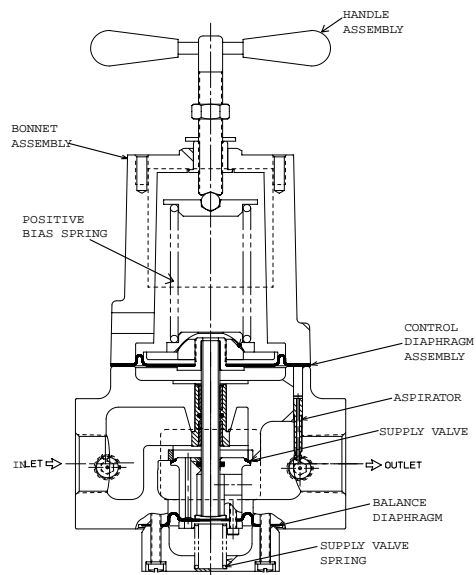

Technical Information

Model 100612
Fairchild Industrial Product Company
2 - 150 psig range

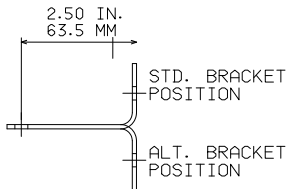
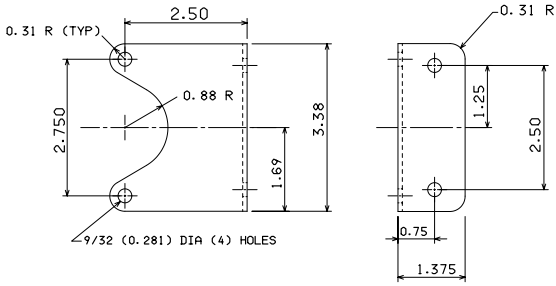
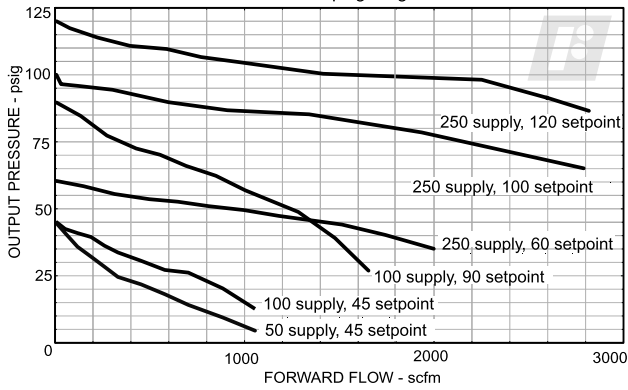

Mounting Bracket: 10308

Model 100 Regulator Kits & Accessories

Mounting Bracket Kit.....10308 (sold separately)

Specifications

Maximum Supply Pressure
250 psig, [17.0 BAR], (1700 kPa)

Flow Capacity
In excess of 1500 SCFM (2550 m³/HR) (100 psig, [7.0 BAR], (700 kPa) supply, 1 1/2" NPT Conn. 40 psig, [2.8 BAR], (280 kPa) setpoint

Exhaust Capacity
44 SCFM (75 m³/HR) for downstream pressure 5 psig, [.35 BAR], (35 kPa) above 20 psig set pressure

Supply Pressure Effect
Less than 0.1 psig, [.007 BAR], (.7 kPa) per 100 psig, [7.0 BAR], (700 kPa) change

Sensitivity
0.5" (1.27 cm) Water Column

Ambient Temperature Limit
-40°F to +200°F, (-40°C to +93.3°C)

Catalog Information

Catalog Number 1 0 0

Pressure Range

psig	[BAR]	(kPa)	
0-10	[0-0.7]	(0-70)	2
0.5-30	[0.035-2]	(3.5-200)	3
1-60	[0.07-4]	(7-400)	4
2-100	[0.14-7]	(14-700)	5
2-150	[0.14-10]	(14-1000)	6

Pipe Size

1" NPT	08
1 1/2" NPT	12

Options

Tapped Exhaust	E
Non-Relieving	N
Tamper Proof	T

Service Information

A Service Kit is available for the Model 100. Refer to the *Fairchild Model 100 High Flow Pressure Regulator Installation, Operation and Maintenance Instructions, IS-10000100.*

Hazardous Locations

Acceptable for use in Zones 1 and 2 for gas atmosphere; Groups IIA and IIB and Zones 21 and 22 for dust atmospheres

Materials of Construction

Body.....Aluminum
TrimZinc Plated Steel, Brass
DiaphragmsBuna N